



LE-8X2NX, 8X8NX

When pumping solutions, make certain that all tubing is securely attached to the fittings. It is recommended that tubing or pipe lines be shielded to prevent possible injury in case of rupture or accidental damage. Always wear protective clothing and face shield when working on or near your metering pump.

Note: See parts list for materials of construction

A. INSTALLING INJECTION CHECK VALVE (FIGURE 1)

1. The Injection Check Valve prevents backflow from a treated line. Install the injection check valve at the location where chemical is being injected into the system.
2. Any size Female NPT fitting or pipe tee with a reducing bushing to 1/2" Female NPT will accept the injection check valve. PTFE tape should only be used on threads that are connected with pipes.
3. When installing the Injection Check Valve, be sure to position it so that the valve enters the bottom of your pipe in a vertical position. Variations 40° left and right are acceptable.

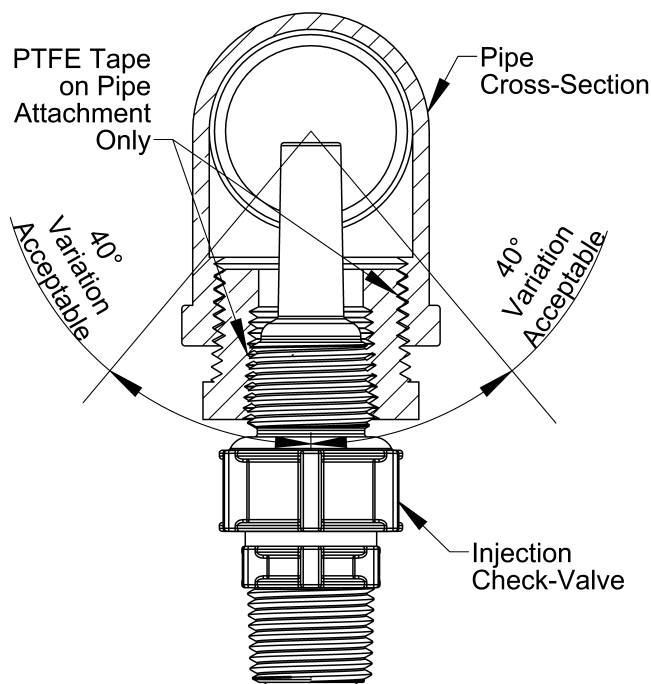

FIGURE 1

B. CONNECTING DISCHARGE TUBING (FIGURE 2)

Note: Cut tubing to length needed for discharge line.

1. Route tubing from the injection check valve to the metering pump, making sure it does not touch hot or sharp surfaces, or is bent so sharply that it kinks.
2. Put coupling nut over tubing.

3. Position female Ferrule about one inch (25 mm) from end of tubing.
4. For 1/4" or 6 mm OD tubing, cut tubing so that 1/4" to 3/8" (5-10 mm) protrudes from the female Ferrule. For all other tubing push the tube to the bottom of the groove in the male Ferrule. Then slide the female Ferrule down into the male Ferrule.
5. Firmly hand tighten the coupling nut onto the fitting.

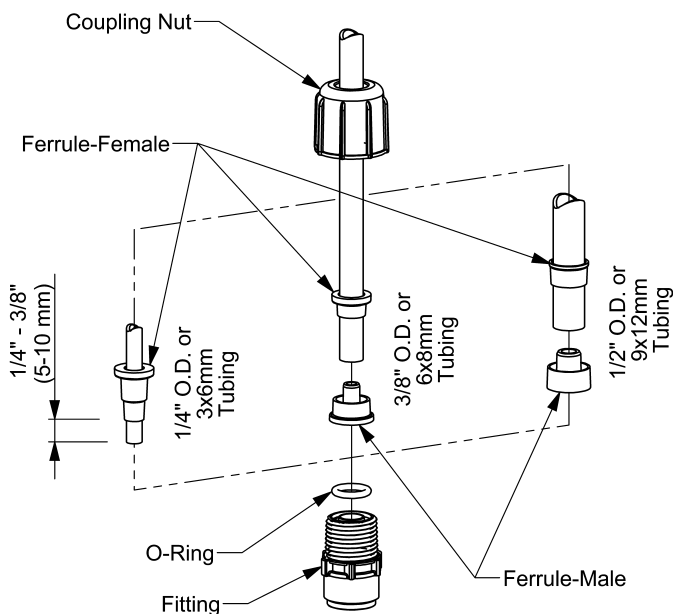

FIGURE 2

DO NOT USE CLEAR VINYL TUBING ON THE DISCHARGE SIDE OF THE PUMP. The pressure created by the pump can rupture vinyl tubing, which is only for connection to the return line of the FastPrime™ fitting.

DO NOT USE PLIERS OR PIPE WRENCH ON COUPLING NUTS OR FITTINGS.

C. CONNECTING SUCTION TUBING

1. Cut suction tubing to a length so that the foot valve hangs just above the bottom of the solution container. Maximum recommended vertical suction lift is 5 ft (1.5m).
2. Follow same procedure in connecting suction tubing to suction valve and foot valve (see **B. Connecting Discharge Tubing**).



201 Ivyland Road
Ivyland, PA 18974 USA
TEL: (215) 293-0401
FAX: (215) 293-0445
<http://www.lmipumps.com>

LE-8X2NX, 8X8NX

Key Number	Description	Part Number	QUANTITY				QUANTITY			
			812NX	822NX	832NX	842NX	818NX	828NX	838NX	848NX
10	Pump Head Molded FastPrime™	48360					1			
		48361	1							
		48363						1		
		48364		1						
		48366							1	
		48367			1					
		48369								1
		48370				1				
40	O-Ring	48349	4	4	4	4	4	4	4	
90	O-Ring	39413	5	5	5	5	5	5	5	
100	O-Ring	36103	4	4	4	4	4	4	4	
140	O-Ring	48590	1	1	1	1	1	1	1	
150	O-Ring	48347	1	1	1	1	1	1	1	
190	Liquifram™	48186	1				1			
		48187		1				1		
		48188			1				1	
		48189				1				1
230	Injection Check Valve Body	48617					1	1	1	1
		48618	1	1	1	1				
250	Ceramic Weight	10322	1	1	1	1	1	1	1	
260	Foot Valve Coupling	36204	1	1	1	1	1	1	1	
270	Foot Valve Strainer	10123	1	1	1	1	1	1	1	
350	Tubing, Suction & Discharge 8XXNI ONLY	25636-16	1	1*			1	1*		
		10342-16		1#	1	1		1#	1	1
	Tubing, Suction & Discharge 8XXNU ONLY	28636-16	1	1*			1	1*		
		27342-16		1#	1	1		1#	1	1
352	Tubing, FastPrime™	10469-06	1	1	1	1	1	1	1	
601	FastPrime™ Discharge Check Valve	48665	1							
		48667		1	1	1				
		48669					1			
		48672						1	1	1
602	Suction Check Valve	48677	1							
		48679		1	1	1				
		48681					1			
		48684						1	1	1
603	Cartridge Valve	48542	4				4			
		48543		4	4	4		4	4	4
604	FastPrime™ Cartridge Valve	48548	1				1			
		48549		1	1	1		1	1	1
605	FastPrime™ Valve	48700	1	1	1	1				
		48848					1	1	1	1
606	Liquid End Hardware	48703	1	1	1	1	1	1	1	
607	Foot Valve	48718					1			
		48721						1	1	1
		48720	1							
		48723		1	1	1				
608	Injection Valve	48728					1	1	1	1
		48731	1	1	1	1				
613	Tubing Connection Kit 8XXNI and 8XXNU	77382	4	4*			4	4*		
		77383		4#	4	4		4#	4	4
	Tubing Connection Kit 8XXNM ONLY	77378	4	4*			4	4*		
		77379		4#	4	4		4#	4	4
615	Single Ball Check Valve Fitting	48788	2	2	2	2				
		48787					2	2	2	2
616	Double Ball Check Valve Fitting	48791					2	2	2	2
		48792	2	2	2	2				
617	Injection Valve Cartridge	48795	1	1	1	1	1	1	1	

ROYTRONIC® Series A pumps

* ROYTRONIC EXCEL™ Series A+ pumps

LE-8X2NX, 8X8NX

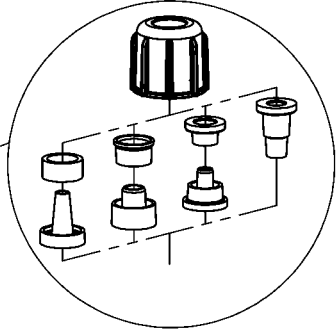
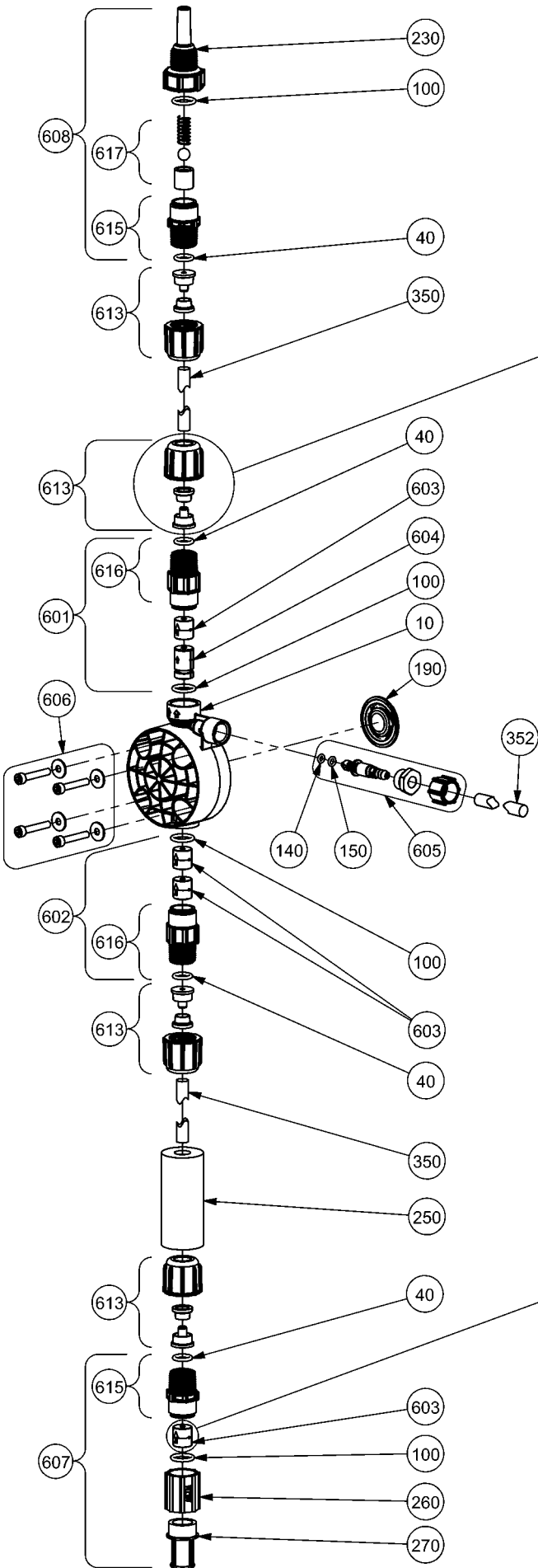

DEPENDENT ON TUBING SIZE,
THE FERRULE GEOMETRY WILL BE DIFFERENT.

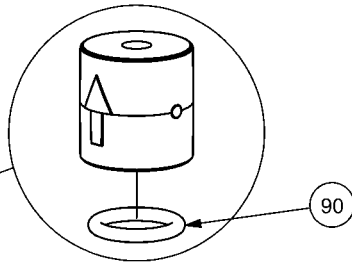

DEPENDENT ON CARTRIDGE DESIGN,
AN O-RING MAY BE PRESENT AS PART
OF THE ASSEMBLY.

D. PRIMING FOR FastPrime™ LIQUID ENDS

1. Connect the 3/8" outer diameter clear vinyl tubing provided with the pump to the FastPrime™ Valve barbed nozzle (Figure 3). Route tubing to the solution tank. This tubing must not be submerged in the solution.

When all precautionary steps have been taken, the pump is mounted, and the tubing is securely attached, you may now start priming the pump.

2. Plug in or switch the pump on.
3. While the pump is running, set at 100% speed and 100% stroke length.
4. Turn The FastPrime™ knob 1 to 2 turns counter-clockwise ⤴.
5. The suction tubing should begin to fill with solution from the tank.
6. A small amount of solution will begin to discharge out the return line of the FastPrime™ valve. Once this happens, turn the knob clockwise ⤵ until hand tight and **SHUT THE PUMP OFF**.
7. The pump is now primed.

Note: The pumps are normally self priming if suction lift is less than 5 feet (1.5 meters), check valves are wet (there is usually water in the pump head when shipped from the factory), and the steps above are followed. If the pump does not self prime, you can choose one of 2 ways to help prime:

1. Remove the discharge valve and discharge cartridges and slowly pour water or solution into the pump head until it is filled. Replace cartridges and discharge valve and repeat steps above.
2. Temporarily improve suction conditions by pumping from a container closer to or above pump.

E. DEPRESSURIZING THE DISCHARGE LINE AND PUMP HEAD

ALWAYS wear protective clothing, face shield, safety glasses and gloves when performing any maintenance or replacement on your pump.

Read steps 1, 2 and 3 below before proceeding.

1. Be sure the Injection Check Valve is properly installed and is operating. If a shut off valve has been installed downstream of the Injection Valve, it should be closed.
2. **Line Depressurization:**
To reduce the risk of chemical splash during disassembly or maintenance, all installations should be equipped with line depressurization capability. Installing a ROYTRONIC® 4-Function Valve is one way to include this capability. Refer to the operating instructions of the valve or device.
3. **Pump Head Depressurization:**
Be sure your relief tubing is connected to your FastPrime™ valve and runs back to your solution drum or tank.
Turn the FastPrime™ knob one-and-a-half turns counter-clockwise ⤴. The Pump Head is now depressurized. Keep the valve open until solution drains into the solution drum or tank. Then turn the FastPrime™ knob clockwise ⤵ to tighten the knob to a closed position.



When tubing connections are loosened, chemical will drain from the line. Use appropriate safety precautions to avoid contact with chemical.

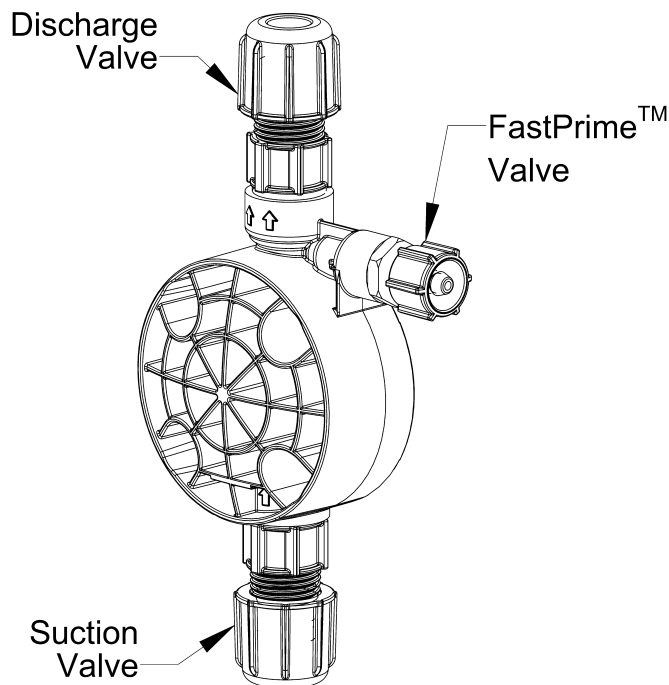

FIGURE 3

REFER TO YOUR ELECTRONIC METERING PUMP INSTRUCTION MANUAL FOR ADDITIONAL INSTRUCTIONS AND PRECAUTIONS. You may contact your local LMI Distributor for additional information or visit LMI on the web at www.lmipumps.com